



QUANTUM™ 4000

4 FLAVOR POST-MIX
JUICE DISPENSER



FEATURES:

- Easy front loading of concentrate
- High performance peristaltic pumps and a unique mixing valve assures elimination of stratification
- Large concentrate storage capacity
- Tamper resistant and disposable packaging
- Modular component design provides ease of sanitation and service
- Contemporary cabinet design is a blend of attractive black plastic and sturdy stainless steel
- Easy-to-adjust mixing system controls and maintains a consistent finished drink
- Lighted merchandiser available
- Push button or programmable portion controlled dispensing available

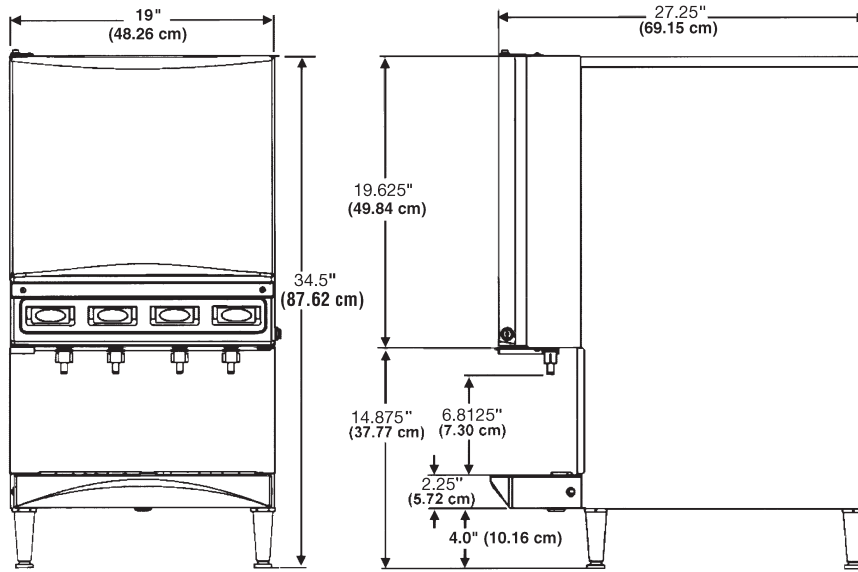

TECHNICAL SPECIFICATIONS:

DESCRIPTION Model SLJ2000-4
 115 V / 60 Hz / 9.43 Amps
 220 V / 50 Hz / 5 Amps

REFRIGERATION 1/3 HP hermetically sealed system
 R-134a refrigerant
 6.25 oz (177 g)

CABINETY Plastic and Stainless steel

DISPENSER DIMENSIONS 34.5"H (with 4" legs) x
 19"W x 27.25"D
 (87.62 cm x 48.26 cm x 69.15 cm)

WEIGHT Dry: 140 lb (58.56 kg)
 Shipping: 156 lb (65.83 kg)
 Max counter 177 lb (80.30 kg)

RECOMMENDED CLEARANCE . . Back: 4" (10.16 cm)
 Top: 12" (30.48 cm)
 and open to the front for air circulation

WATER CONNECTION 0.375" (0.95 cm) SAE male flare fitting on dispenser

CONCENTRATE STORAGE 676 oz (20 L)

WATER SUPPLY REQUIREMENTS 80 psi (5.6 kg/sq cm) max static pressure
 20 psi (1.4 kg/sq cm) min dynamic pressure

COOLING CAPACITY 4 continuous 5 oz (147.85 mL) drinks/min with 75°F (24°C) concentrate without exceeding 45°F (7°C) drink temp

FLOW RATE Adjustable water flow rate from 1.6 oz/sec (47.31 mL/sec) to 2.2 oz/sec (65.05 mL/sec); Handles 2 + 1 - 7 + 1 concentrate

OPTIONAL ACCESSORIES 160 oz (4.7 L) HDPE refillable concentrate container, Illuminated merchandiser, Portion control, Sanitizing tank kit, Extended splash panel kit (lowers drink tray)

AGENCY LISTINGS   